

Urządzenie do mieszania i nakładania klejów

Установка для смешивания и наклейки клеев

Anna RUDAWSKA

DOI: 10.15199/160.2019.3.7

Abstract: The aim of the present article is to present the design concept of a specialized device for mixing and applying adhesives (one and two-component ones) intended for unit production or laboratory use. The paper presents the initial assumptions of the device design, such as the type of production, application method and adhesive properties. Technological requirements for the adhesive mixing and applying device were enumerated. The technological requirements will include the characteristics of the method of adhesive application. The construction requirements of the designed device are also presented. The design of this device has been presented in the form of a 3D model, made with use of the SolidEdge software. The advantages and limitations of the concept of the designed device were also presented.

Keywords: bonding, device, mixing, application, adhesive

Streszczenie: Celem niniejszej pracy jest przedstawienie koncepcji projektu specjalizowanego urządzenia do mieszania i nakładania klejów (jedno- i dwuskładnikowych), przeznaczonego do produkcji jednostkowej lub do zastosowań laboratoryjnych. W pracy przedstawiono założenia wstępne projektu urządzenia, takie jak: rodzaj produkcji, sposób nakładania oraz właściwości kleju. Przedstawione zostaną także wymagania technologiczne stawiane urządzeniu do mieszania i nakładania kleju. Wśród wymagań technologicznych wymienia się m.in. sposób nakładania kleju. Przedstawiono także założenia konstrukcyjne zaprojektowanego urządzenia klejarskiego. Projekt tego urządzenia został przedstawiony w formie modelu 3D, wykonanego za pomocą programu SolidEdge. Zaprezentowano także zalety oraz ograniczenia koncepcji zaprojektowanego urządzenia.

Słowa kluczowe: klejenie, urządzenie, mieszanie, nakładanie, klej

Introduction

The process of bonding technology includes a series of operations aimed at obtaining an adhesive joint with specific characteristics [3, 6, 7]. The bonding technology process includes the following operations: surface preparation, adhesive preparation, adhesive application, fixing and bonding the elements, curing the adhesive joint, joints control, finishing operations [5, 8, 13]. The bonding technology process described in the aforementioned operations also includes several indirect activities, and the whole process is carried out with use of various tools and devices (often the specialised ones) that are necessary to make a proper adhesive joint [9, 10, 11].

The stages of the bonding process analysed herein are the adhesive mixing and applying, whereas they may be analysed both separately and together. Due to this fact it is possible to enumerate both the tools and devices dedicated to specific operations of the bonding technology process and those that combine the functionalities of mixing and applying the adhesives [4, 10, 12].

The adhesive preparation process is a key stage of the bonding technology process. The appropriate mixing of the adhesive components plays a vital role in the bonding process [4, 5, 7]. In case of the two-component adhesives it is important to make sure that all the

components (added in proper amounts, often based on the stoichiometric ratio of some components) are mixed properly and thoroughly so that the adhesive mixture obtained is homogenous [2, 5]. Also, it is necessary to ensure that the adhesive compound does not contain any air bubbles as it may result in improper bonding of the joined materials and affect the adhesive joint's strength. In this type of operation both the manual and mechanical methods are used. Both of them require proper tools and devices, though. In order to obtain a proper adhesive joint, it is necessary to apply the appropriate adhesive layer on the bonded surfaces. For different types of production (piece or batch), the process of applying the adhesive may be automated by using proper devices, tools or appliances [4, 5, 8, 11].

There are lots of devices used in the operations of adhesive preparing and applying. They are offered by different producers (in most cases the producers of adhesives). Also, they are sometimes designed especially for the purposes of a specific bonding process [1, 2, 8, 9, 12].

The present article is aimed at elaborating a concept of the project of a specialised device for mixing and applying adhesives (one and two-component ones) aimed at piece production and laboratory work, based on the existing construction solutions.

The concept of the adhesive mixing and applying device

• Technological, construction and performance assumptions

The condition for the proper design of the adhesive mixing and applying device is to meet numerous construction and technological requirements affecting the correctness of the adhesive application process. The designed device should serve the specified functions, as well as enable to obtain the repeatability of the adhesive application process. The following technological and performance assumptions were made:

- the possibility of mixing two components of an adhesive (e.g. resin and curing agent in case of epoxy adhesives),
- precise dosage of the prepared (mixed) adhesive,
- the repeatability of the adhesive application process,
- the possibility of applying the adhesive on the surfaces of irregular shapes,
- the possibility of changing the way of applying the adhesive (tracks, drops),
- the possibility of a quick adhesive refill,
- the possibility of quick cleaning the adhesive containers after the application process, due to the use of additional "inserts" in the form of disposable containers placed in the adhesive containers,
- ease and speed of maintenance.

The assumptions presented hereinabove enable to elaborate the concept of design of a device that, when used properly, will improve and rationalize the adhesive application process. Setting a proper amount of the adhesive compound to be applied, as well as shorter application time will enable to apply the adhesive mass properly in the form of drops or tracks.

• Construction assumptions

A 3D model of the adhesive mixing and applying device presented in Figure 1 was designed based on the construction of devices produced by ABM [1], specialised in, among others, construction and production of devices for the bonding process. The basic elements of this specialised tool are presented in Figure 2. The concept elaborated included some changes in terms of dimensions and construction of containers for the adhesive's components (or the adhesive itself in case of one-component adhesives). Also, there were some changes in the construction of the mixing-dosing nozzle and the possibility of two variants of the adhesive application on the surface was added.

The construction assumptions of the adhesive mixing and applying device included, among others, the overall dimensions of the device (Fig. 2), i.e.:

- total height: 410 mm,
- base dimensions: 300 x 400 mm,
- adhesive containers total spacing: 327 mm,

The adhesive containers are made of stainless steel (1.4301) and contain additional "inserts" in the form of disposable containers placed inside of them. In addition,

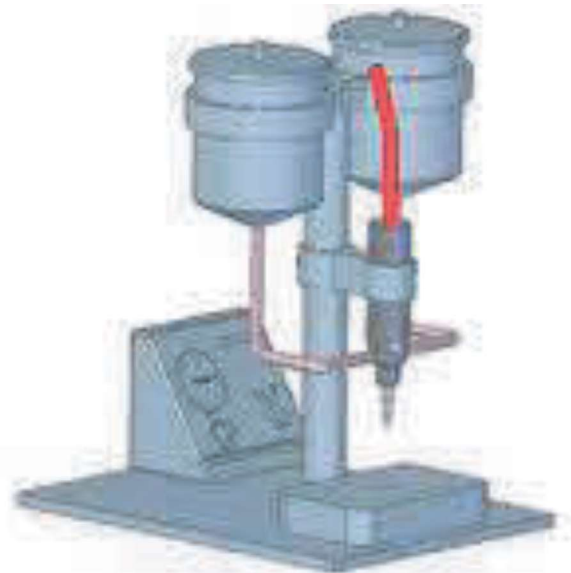

Fig. 1. A 3D model of the adhesive mixing and applying device
Rys. 1. Model 3D urządzenia do mieszania i nakładania kleju

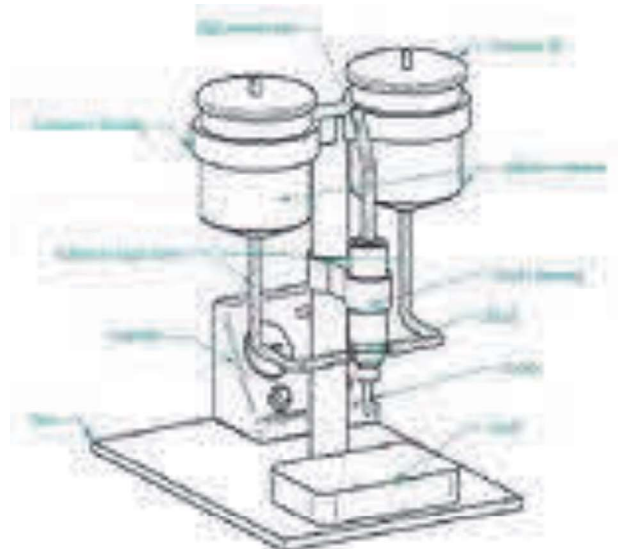

Fig. 2. General arrangement diagram of the adhesive mixing and applying device
Rys. 2. Schemat ogólny urządzenia do mieszania i nakładania kleju

they are equipped with lids protecting the adhesive from external conditions and impurities (e.g. dust). The containers' capacity is 1.5 l.

The device's base is equipped with a special work table (stand) that can be used to place the objects being covered with the adhesive firmly and directly under the dosing head.

The head's fastening is made of stainless steel (1.4301). The hole made in the fastening together with the knob enable to adjust the head's height in order to cover the objects of bigger dimensions with the adhesive.

The hoses supplying the adhesive are made of silicone with the diameter of 10 mm, which makes them more flexible. The compressed air pipe with a diameter

of 12 mm is a universal pipe aimed at pneumatic devices with the operating pressure of up to 1.5 MPa, made of combination of rubber with polyvinylchloride (SBR + PVC). It is characterised by high wear and bending resistance.

• **Description of adhesive mixing and applying**

The process of adhesive mixing in the designed device takes place in the dosing nozzle. Its special construction allows for proper mixing of the two-component adhesives directly before the operations of dosing and applying the adhesive on the bonded surfaces. Thanks to that it takes much less time to bond the elements as an additional operation of preparing the adhesive is eliminated. The adhesive that flows off from the containers is forced through by a small piston located in the head. It is driven by compressed air supplied from the compressor to the head. When the proper pressure is obtained, the adhesive flows into the dosing-mixing nozzle where it is mixed by a mixer located in the dosing nozzle.

The designed device is equipped with a proper dosing-mixing head (Figure 2), which, with use of a proper controller, enables to adjust the amount of adhesive and the way of its application on the bonded surface. The dose of the adhesive is strictly related to the amount of the compressed air supplied, which steers the small piston in the dosing head. The piston opens, i.e. feeds the adhesive and, at the same time, pushes it out through the nozzle onto the bonded surface. When the piston closes it makes it impossible to supply an undesirable dose of adhesive and, as a result, eliminates so called dripping.

The component parts of the adhesive spreader that is the key element of the adhesive mixing and applying device are presented in Figure 3, whereas the 3D model is shown in Figure 4.

Such construction of the adhesive head enables to apply the adhesive in two possible variants presented below:

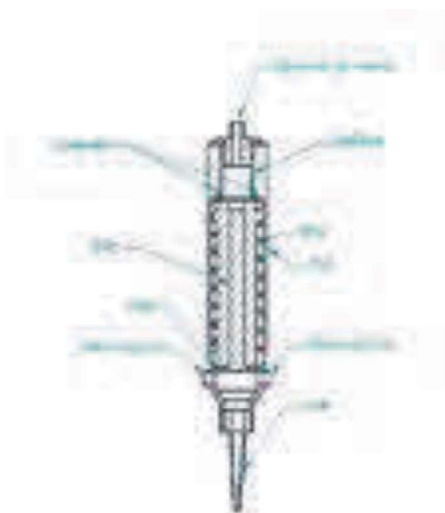

Fig. 3. Construction of the adhesive spreader's head
Rys. 3. Budowa głowicy nakładarki do kleju



Fig. 4. A 3D model of the adhesive spreader's head
Rys. 4. Model 3D głowicy nakładarki do kleju

- in the form of single adhesive doses (drops) - Figure 5a, application of adhesive in the form of single drops enable to bond, among others, small objects,
- in the form of a uniform stream (track) - Figure 5b.

The designed device is equipped with a controller with a manometer that controls the device. The controller enables to regulate the operating pressure in the adhesive spreader's head pneumatic system and prevents from deviations related to the pressure decrease and the change of the adhesive dose. Thanks to the manometer used in the device it is possible to observe the pressure in the pneumatic system that steers the head and to set a proper dose of adhesive. The device control switch enables to set the right dose of adhesive from two ranges: 25 ml and 50 ml.

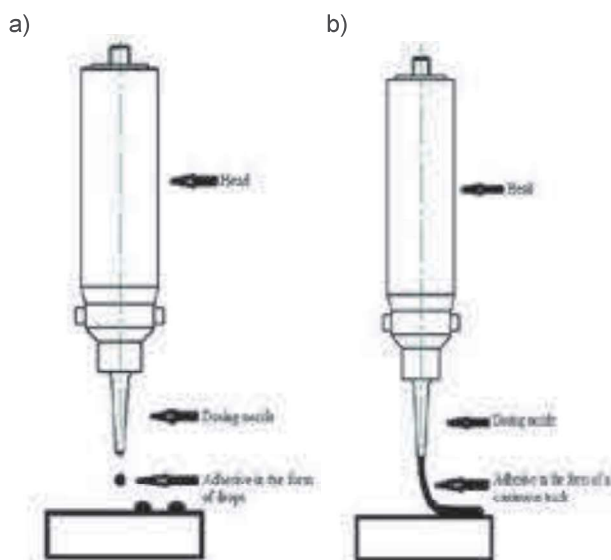

Fig. 5. Adhesive's application: a) in the form of single drops, b) in the form of a continuous track (stream)
Rys. 5. Aplikacja kleju: a) w postaci pojedynczych kropeł, b) w postaci jednostajnego strumienia

• *Advantages and limitations of the device*

The advantages of the adhesive applying device concept described herein include:

- the possibility of dosing adhesive from two ranges: 25 ml and 50 ml,
- simple and functional construction,
- the possibility of changing the way of applying adhesive (tracks, drops),
- simple and user-friendly interface,
- dosing accuracy,
- the possibility of applying two-component adhesives without the need of mixing them beforehand,
- stable and durable device base,
- small dimensions,
- the construction made of stainless steel to eliminate possible corrosion of different elements,
- a standard adhesive container capacity for multiple dosing without the need of refilling the adhesive,
- the use of disposable nozzles to shorten the cleaning time after finishing the bonding process,
- shorter time of adhesive application thanks to the use of a mixing-dosing nozzle,
- simple construction for faster cleaning of the whole device,
- the possibility of setting the head height for bonding the elements of different dimensions.

The limitations of the adhesive mixing and applying device are the following:

- the overall dimensions of the elements covered with adhesive depend on the dimensions of the work table,
- the possibility of applying the adhesive only in two specified doses,
- no possibility of heating up the adhesive during application,
- no possibility of connecting the device to external sources for feeding the adhesive,
- limitations related to using fillers.

Summary

The concept of device presented herein allows for mixing and applying both one and two-component adhesives. Thanks to the use of a special head, two variants of adhesive application are possible - in the form of tracks and drops. The possibility of regulating the adhesive application variant enables to increase the possibilities of the device' usage in the bonding process. Applying the adhesive in the form of single drops makes it possible to bond small elements precisely as the adhesive dose is small and accurate. In turn, applying the adhesive in the form of tracks (stream) enables to bond bigger and much longer elements. Precise dosing of the adhesive compound prevents from different issues related to insufficient bonding. It is due to the fact that the adhesive fed in the form of tracks through the dosing nozzle is applied in a continuous way, which eliminates the shortages that result from improper dosing.

The small overall dimensions of the designed device are its considerable advantage as it takes up very little space in properly managed workshop and production spaces.

References

- [1] ABM catalogue (<https://amb.pl/>, retrieved on 29.03.2019)
- [2] Axentowicz M., Karpiński J.: Kleje jedno- i dwuskładnikowe produkcji Ciba-Geigy oferowane jako Araldit 2000 oraz Araldit 4000. [One and Two-Component Adhesives produced by Ciba-Geigy offered as Araldit 2000 and Araldit 4000]. *Technologia i Automatykacja Montażu 2* [Assembly Technology and Automation 2]. (1994) 43–46.
- [3] Board E.: Adhesive Technology and Formulations Hand Book. Retrieved from: <https://dehatipustakbhandar.com> (retrieved on 28.03.2019 r.)
- [4] Cagle C. V. (red.), Kleje i klejenie. Poradnik inżyniera i technika. [Adhesives and Bonding. A Guide for Engineers and Technicians]. PWE, Warszawa 1977.
- [5] Czaplicki J., Cwikliński J., Godzimirski J., Konar P.: Klejenie tworzyw konstrukcyjnych [Construction Materials Bonding], WKiŁ, Warszawa 1987.
- [6] Ebnasajad S.: Adhesives technology handbook. 2 nd edition. Inc. Norwich, William Andrew, NY, USA 2008.
- [7] Godzimirski J., Kozakiewicz J., Łunarski J., Zielecki W.: Konstrukcyjne połączenia klejowe elementów metalowych w budowie maszyn. [Constructional Adhesive Joints of the Metal Elements in Mechanical Engineering]. Oficyna Wydawnicza Politechniki Rzeszowskiej, Rzeszów 1997.
- [8] Kuczmazewski J., Technologia śmigłowców, Teoria i technika klejenia. [Helicopters Technology. Bonding Theory and Technology]. Wydawnictwo Uczelniane Politechniki Lubelskiej, Lublin 1990.
- [9] Łunarski J.: Połączenia klejone w procesach montażu. [Adhesive Joints in the Assembly Processes]. *Technologia i Automatykacja Montażu 2* [Assembly Technology and Automation 2] (1994) 2–5.
- [10] Rudawska A.: Mieszanie, dozowanie i nakładanie kleju w montażu automatycznym. [Mixing, Dosing and Applying adhesives in Automated Assembly]. 11th International Conference „Automation In Production Planning and Manufacturing”, 03 – 05 May 2010, Žilina- Turciańskie Teplice, Slovak Republic, 208–213.
- [11] Rudawska A.: Oprzyrządowanie w technologii klejenia. [Instrumentation in the Bonding Technology]. Wydawnictwo Uczelniane Politechniki Lubelskiej, Lublin 2016.
- [12] Sarnow L.A.: Urządzenia do nakładania hermetyków, smarów i cyjanoakrylowych klejów. [Tools for Applying Locking Paints, Lubricants and Cyanoacrylic Adhesives]. *Technologia i Automatykacja Montażu 1* [Assembly Technology and Automation 1] (1993) 34–36.
- [13] Sedliak J., Mamiński M.: Gluing process' conditions Wydawnictwo SGGW, Warszawa 2015.

Anna Rudawska, PhD. Eng., is the Associate Professor at Department of Production Engineering, Faculty of Mechanical Engineering, Lublin University of Technology; address: ul. Nadbystrzycka 36, 20-618 Lublin, Poland, a.rudawska@pollub.pl